

Volkmann Bulk Bag Unloading Stations



Systems and Solutions for the
Hygienic and Safe Handling of Powders
for the Chemical, Food,
Pharmaceutical and Pigment Industries

Bulk Bag Unloading Stations



Built to be used independently or as part of a complete Volkmann conveying system, our Bulk Bag Unloading Station (BBU) is engineered and manufactured to the same exacting quality standards as our vacuum conveyors.

Its modular design allows you to customize the unit to meet your specific usage requirements in either a hoist or forklift configuration. In addition, the BBU is designed to optimize dust-free material flow from the bag to the vacuum conveyor and down line processes without any contamination of the material or work environment. It does this by using a patent-pending dust tight discharge chute connector, which keeps product flow

contained and prevents material that has collected on the underside of the bulk bag from contaminating the product.

The Volkmann BBU Station features:

- Unloading capability for Bulk Bags up to 2 tons
- Modular design
- Custom configuration
- Heavy duty tubular frame construction suitable for today's industrial use
- Carbon steel painted or all stainless steel frame
- 316L Stainless steel contact parts
- Low profile
- Loading by fork lift or with integrated crane and hoist
- Dust-free connection and emptying of Bulk Bags
- Dust aspiration during the change of a Bulk Bag
- Contaminant free bag loading – no foreign matter from the bottom of the bag enters the material flow
- Optional lump breaker and extra agitator
- Flow assisting massagers or vibration assistance
- Dust filter option
- Combined systems with Bag Rip-and-Tip Station available
- Vacuum conveyor interface

BBU options include:

- Massaging paddles with pneumatic actuators
- Manual or pneumatic covering for the material discharge module
- Material agitator
- Material delumper
- Dust collector
- Volkmann conveyor interface

Bulk Bag Unloading Stations

Contained Dust-Free Bag Connection



Adaption of the Big Bags on Docking Station



Manual Adjustment Via Two Arms



Massager Unit to Assist Discharge

Bulk Bag Unloading Stations

BBU Standalone Hopper Discharge

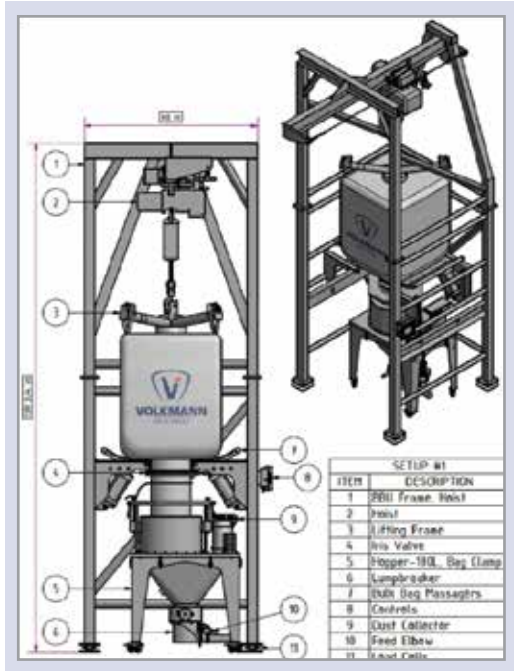

With Hoist

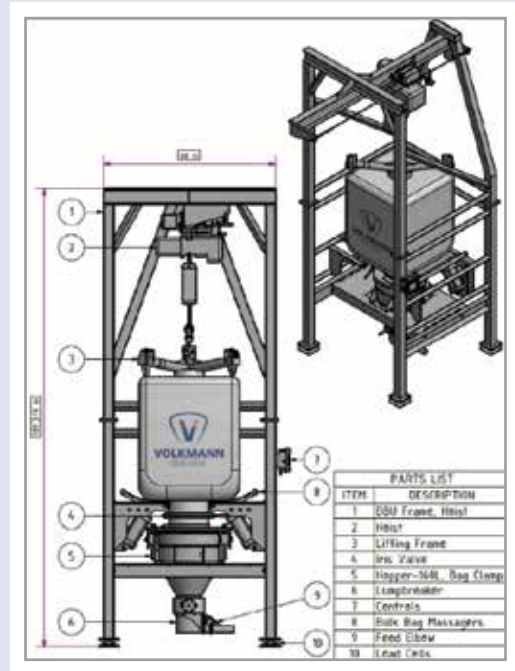

With Hoist

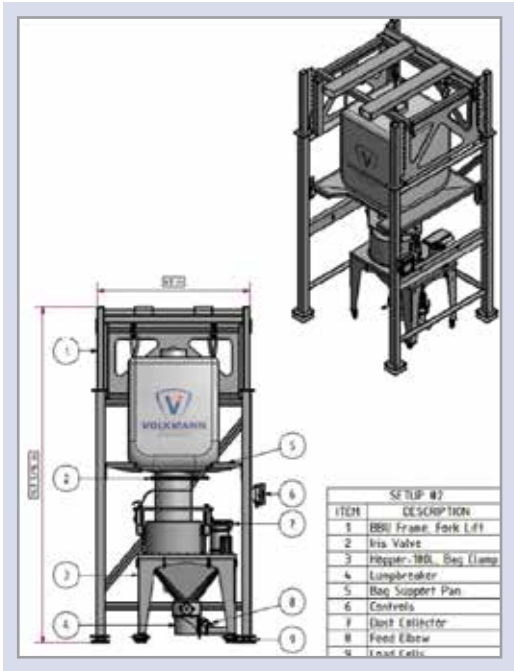

Fork Lift Type

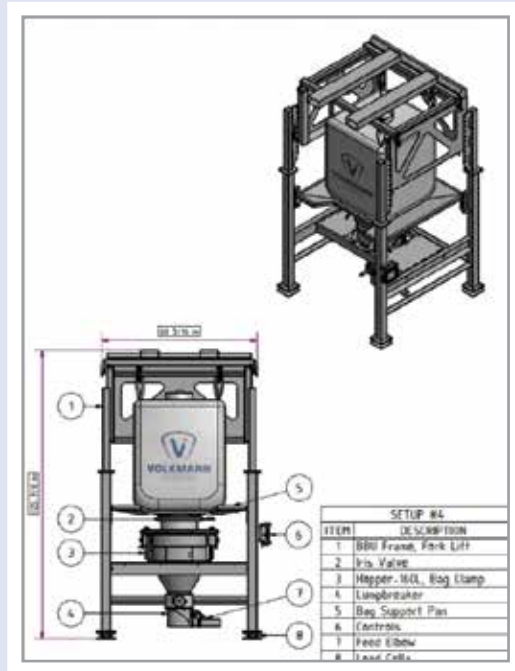

Fork Lift Type

Bulk Bag Unloading Stations

BBU With Lump Breaker

Volkmann's lump breakers and material agitators for agglomerates and lumps can easily be docked to the BBU.

They allow for vacuum transport in a closed system free of emissions. Easy to disassemble and clean, they can also be flushed without a removal from the BBU.



Massager System Flow Aid



AREA OF
DETAIL



Dust Containment Filter

A Volkmann filter-based dust collector localized on the discharge hopper maintains air quality by containing the vented product. This filtering thereby reduces product losses and keeps the surrounding area clean to avoid unnecessary explosions and safeguard employee health.

The unique "no-tools" required construction of the filter with its Quick Exchange design makes the occasional filter maintenance easy and accessible from the floor.



Bulk Bag Unloading Stations



Left: Hoist static BBU with pneumatic conveyor product discharge.

Top: BBU base frame discharge hopper and bag container.

Bottom: Mobile fork lift BBU with optional massage paddles.

Bulk Bag Unloading Stations

Twin Set Up Saves Production Time



A twin BBU with common discharge hopper overcomes lost time through bag changes.

Volkman Vacuum Conveyors



All Volkman Unloading Stations function seamlessly with Volkman Multijector® Vacuum Conveyors to provide dense phase vacuum conveying without segregation, damage or abrasion. With Volkman conveyors and unloaders, you can optimize material flow from the supply side to the downstream packaging operation. When used with a level-controlled buffer hopper, Volkman conveyors can transfer from as little as 10 lbs./hr. to 6 tons/hr. over distances up to 200 feet, all in dust-free, operator-friendly, and healthy conditions providing sanitary, safe, trouble-free conveying. Choose Volkman for the optimal transport of powders, granules, food particles, pellets, capsules, tablets and other bulk materials.

